

# **SIGNODE** **LBX-2000**™

*Plastic strapping machine*

*Jam-resistant  
technology*

*Automatic  
strap feed*

*Up to  
**70**  
straps per  
minute!*



**SIGNODE**®

Made in  
the U.S.A.

# SIGNODE LBX-2000™

Plastic strapping machine

Signode's new LBX-2000™ offers the most reliable performance, lowest maintenance cost and highest speed of any general duty strapping machine on the market today.

- Up to 70 straps per minute
- Jam-resistant technology
- Automatic refeed
- Lubrication-free
- No internal adjustments necessary

## Easy coil loading

Strap coil pays off from either direction making loading simpler than ever.



## Fully accessible strap path

Raise the hinged tabletop to open the chute. Lift guide for full access to strap path.



## Easy maintenance

No belts or clutches. Hot knife can be removed and cleaned without the use of any tools.

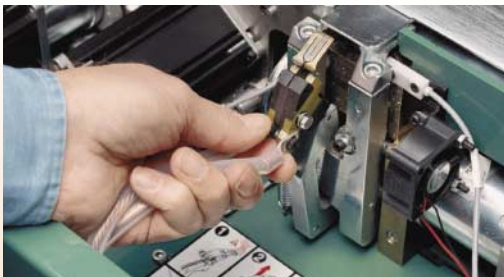

## Save up to 20% on material costs with LB Series plastic strapping

The new LBX-2000 utilizes Signode's newest Contrax® polypropylene strapping. LB Series strapping has the same durable properties as regular Contrax with more strap per coil.

- LB 112 5mm Contrax coils — 30,000 feet per coil
- LB 212 6mm Contrax coils — 24,000 feet per coil

## LBX-2000 Specifications

**Cycle rate:** Up to 70 straps per minute

**Strap size:** 5mm or 6mm wide polypropylene strapping

**Minimum package size:** 2" x 1" (50mm x 25mm)

**Strap tension:** Adjustable from 2 lbs to 60 lbs

**Machine dimensions:** 31" W x 21" L x 57" H (790mm W x 530mm L x 1450mm H), maximum height

**Tabletop height:** 34" (865mm)

**Electrical requirements:** 110 volt, 60Hz

**Shipping weight:** 540 lbs

**Chute inner dimensions:**

	Small chute		Large chute	
	inches	mm	inches	mm
<b>A</b>	20	510	28	710
<b>B</b>	15	380	15	380

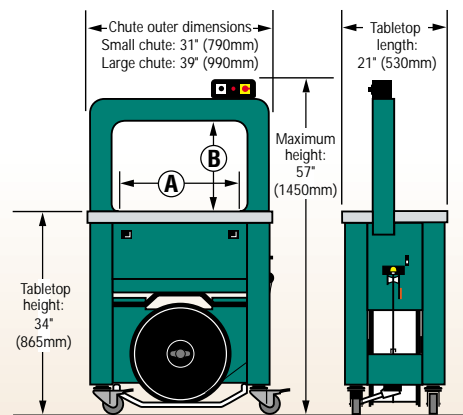

## Options

- 3-stage electric photo eye
- Remote cycle switch

**SIGNODE®**

180 Hastings Dr  
Buffalo Grove, IL 60089